

## Aeration/vent valve Type BE 891/991

## Aeration valve Type B 895/995



type BE 891 or B 895  
DN 10 up to DN 50



type BE 991 or B 995  
DN 65 and DN 80

### High-grade materials for long life

- Housing of uPVC, PP or PVDF
- Float / ball of PP
- Pressure ring of uPVC, PP or PVDF
- Spring of steel, ECTFE (Halar)-coated
- O-ring sealings in FPM

### Reliable and low-maintenance

- Sizes: type 891/895 DN 10 up to DN 50
- Sizes: type 991/995 DN 65 and DN 80
- Operating pressure 10 bar (PN 10)
- Medium-controlled

### Easy fitting of valves to pipe

- Connection: type 891/895 with spigot ends for solvent welding acc. to DIN 8063 or spigot ends acc. to DIN 16962
- Connection: type 991/995 with unions and union ends acc. to DIN 8063 or DIN 16962

### Type BE 891/991 function

Valves of type series BE 891/991 are used for aeration and venting of process plants. In depressurized state or when a fluid level drops (system pressure below atmospheric pressure) air or protective gas enters the plant via the valve. When the fluid level rises the air or gas escapes by the same way until the float/ball rises and hermetically seals the upper valve seat.

**Due to function only vertical mounting is possible.**

### Type B 895/995 function

Valve of type series B 895/995 are used for aeration of process plants. When pressure drops, e.g. when a fluid level drops, the float/ball opens against the spring force and atmospheric air or protective gas enters the plant via the valve. When the pressure or fluid level rises the spring force closes the valve and the float/ball hermetically seals the upper valve seat.

**Due to function only vertical mounting is possible.**

### Notes

When the valve is closed it can only be released when the system pressure falls below the atmospheric pressure even with air build-up in the area of the sealing seat.

**The opening pressure of the float/ball is approx. 0.05 bar.**

This figure considerably depends on the temperature, the system pressure, the medium and the general degree of pollution (crystallization) etc.

**Attention:** In tank installations the use of type BE 891/991 and B 895/995 valves must be checked by the customer as to the safety requirements.

## Technical data

### Type of fluids

Solid-free neutral, aggressive or gaseous liquids provided that the selected materials are resistant at operating temperature. Refer to the ASV resistance guide.

### Pressure/temperature diagram

The values are a guide for harmless fluids (DIN 2403) the material of the valve is resistant against. The pressure/temperature limits are applicable for a computed operating life factor of 25 years at PN 10.

Durability of wear and tear parts is depending on the operating conditions of the application.

Values < 0 °C (PP < +10 °C) on request with exact data of operation.

### Media temperature

Depends on the operating conditions (system pressure, load etc.). Taking creep strength into account, the following approximate temperatures apply:

- uPVC: + 60 °C
- PP: + 70 °C
- PVDF: + 70 °C
- FPM: + 70 °C

### Actuation

fluid controlled

### Installation

- vertical installation only
- take care of correct direction (»TOP«)

### Marking

according to DIN EN 19

## Pressure/temperature diagram<sup>1)</sup>

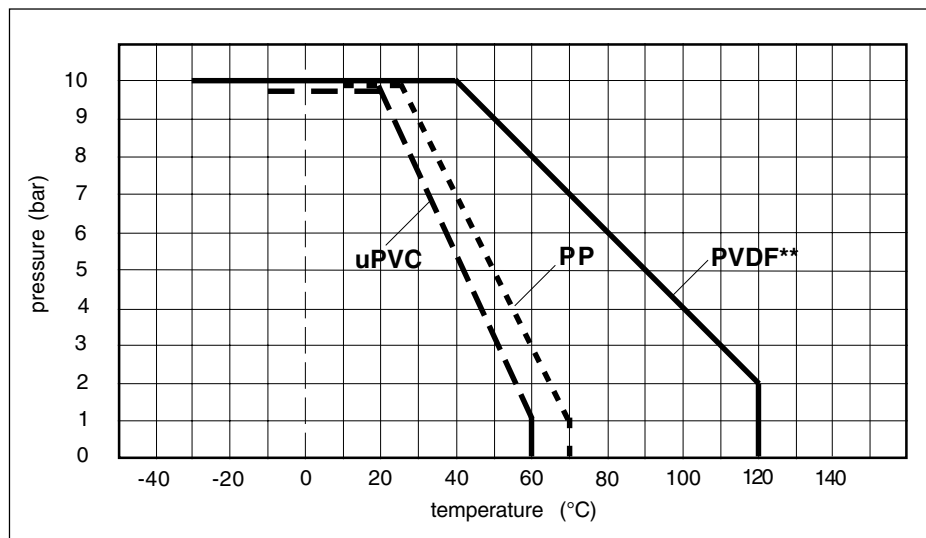

## Dimensional drawing

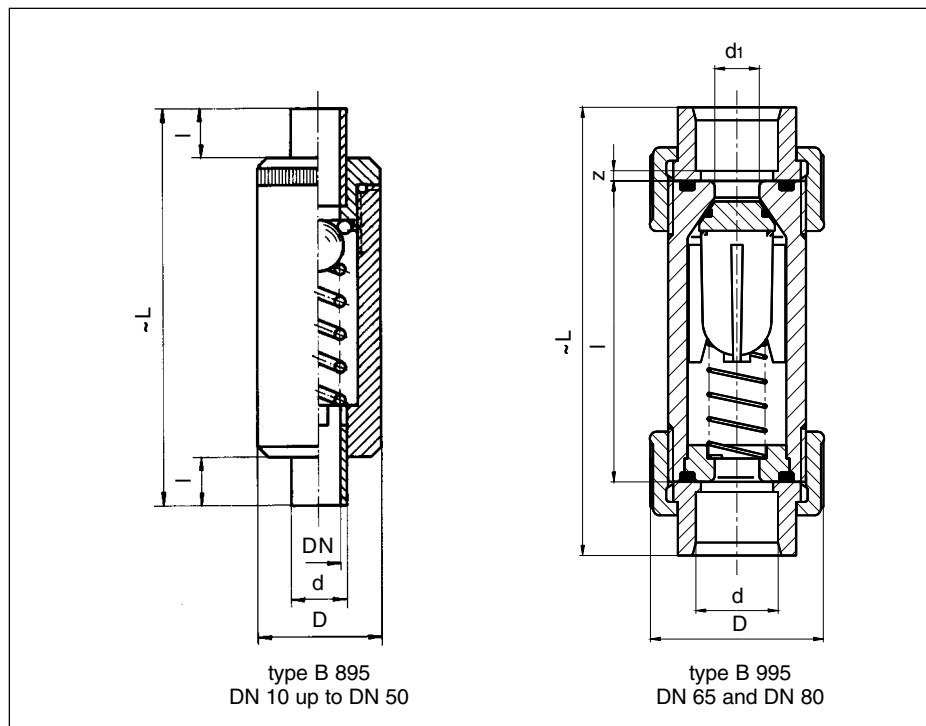

size		dimension						weight g <sup>4)</sup>	flow rate Nm <sup>3</sup> /h <sup>3)</sup>	ident No. <sup>2)</sup>					
d mm	DN mm	DN inch	D mm	~L mm	l mm	d <sub>1</sub> mm	z mm			type BE 891/991			type B 895/995		
								uPVC FPM	PP FPM	PVDF FPM	uPVC FPM	PP FPM	PVDF FPM		
16	10	3/8	35	114	14	-	-	98	10	54393	55959	64153	54405	56783	67257
20	15	1/2	40	124	16	-	-	128	14	54395	54402	67755	54406	55689	67749
25	20	3/4	45	144	19	-	-	190	18	54396	55618	60664	54407	56779	67750
32	25	1	55	154	22	-	-	285	40	54397	54403	60626	54408	54413	60627
40	32	1 1/4	70	174	26	-	-	505	60	54398	60935	67756	54409	60673	67751
50	40	1 1/2	80	194	31	-	-	705	75	54399	56403	64072	54410	56863	64073
63	50	2	95	224	38	-	-	1225	85	54400	65540	64106	54411	56630	64107
75	65	2 1/2	134	254	160	57.5	3	1800	180	120473	120474	<sup>2)</sup>	120482	120483	<sup>2)</sup>
90	80	3	134	270	160	57.5	5	1800	180	118838	118833	<sup>2)</sup>	118846	118842	<sup>2)</sup>

## Operating instructions



Safe operation of the valve can only be ensured if it is properly installed, operated, serviced or repaired by qualified personnel according to its intended use while observing the accident prevention regulations, safety regulations, standards and technical regulations. The intended use includes adhering to the specified limit values for pressure and temperature as well as the chemical resistance referring to the operating conditions.

For this purpose, ensure that all components getting in contact with the media are "**resistant**" in accordance with the ASV resistance guide.

**Connect the aeration and vent valves with a leakage pipe. Non-observance may lead to serious personnel injuries due to leaking medium.**

**The owner/operator bears the sole responsibility for the consequences.**

**The owner/user of the plant or the ordering party for assembly/disassembly work bears full responsibility for**

- assuring that the work protection and accident prevention regulations are adhered to
- the employees to work in a safe manner by consideration of thermoplastic characteristics and respective safety regulations. Informing the employees and involved personnel of potential danger by the medium/plant
- disposal of all used media/waste in accordance with regulations and directives

### Disassembly and assembly

- Close the pipeline valves upstream and downstream the aeration/vent valve BE 891/991 or aeration valve B 895/995 for shut-off prior to commencing any work.
- Ensure a safe pressure release in the pipeline.
- Fully drain the lines taking into account the accident prevention regulations or similar.
- Avoid leakage of hazardous media (emissions).

## Part list and sectional drawing

Part	Piece	Description
1	1	housing
2	1	float or ball
3	1	pressure ring
4	2	union nut
5	2	union ends
6	2	O-ring sealing
7	1	O-ring sealing
8	1	spring (not for type 891/991)
9	1	upper part

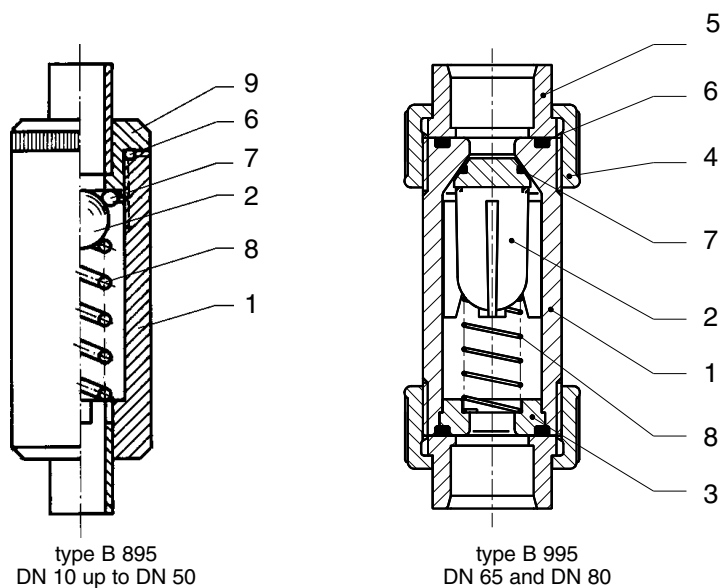

### Disassembly type 991/995

- Unscrew the union nuts (4) and take the valve radially out of the pipeline.
- Remove the O-ring sealings (6) using a blunt tool.
- Turn the valve to the horizontal for disassembly.
- Remove the pressure ring (3) using a suitable tool.

**Attention** As to type B 995 remove the pressure ring with care as the spring (8) may be pretensioned.

- Remove the spring (8) (type B 995).
- Remove the float (2).
- Remove the O-ring sealing (7) using a blunt tool without damaging the O-ring sealing ring groove.

### Disassembly type 891/895

- Unscrew the upper part (9) from the housing (1).

**Attention** As to type B 895 the ball (2) can be under pretension.

- Remove the O-ring sealing (7) using a blunt tool.
- Remove the ball (2) and spring (8).

### Assembly

- Wet and insert new O-ring sealings (7,6) with water or standard commercial detergent (lubrication).
- Complete assembly in reverse order to disassembly described above.

**Attention** At installation take care of correct direction of flow of the valve.

- After every disassembly/assembly and prior using it again all connections are to be checked for leakages.

**Note** Elastomeres, especially the EPDM sealing elements, should not be touched or cleaned with synthetic oils, mineral oils, fats or cleaning agents. Danger of swelling. Only appropriate fats should be used, e.g. silicone greases.



**Stübbe**®

ASV Stübbe GmbH & Co. KG • Hollwieser Straße 5 • D-32602 Vlotho • Fon +49 (0) 57 33.7 99-0 • Fax +49 (0) 57 33.7 99-2 00 • [www.asv-stuebbe.de](http://www.asv-stuebbe.de) • [contact@asv-stuebbe.de](mailto:contact@asv-stuebbe.de)